

1. BE SURE TO ORIENT THE PEDAL CONTACT ASSEMBLIES AS SHOWN RELATIVE TO THE TOE AND HEEL ENDS OF THE PEDALBOARD.

2. INSTALL THE CONTACTS AS FAR TO THE TOE END OF THE KEYS AS POSSIBLE BECAUSE THIS WILL MINIMIZE ANY HYSTERESIS.

3. INSTALL CROSS RAIL IF APPLICABLE.

4a, 4b, 4c. USE LOCATING JIG AS SHOWN TO MARK HOLES AND FELT EDGE LOCATIONS.

5. DRILL PILOT HOLES.

6. CLEAN PEDAL KEY SURFACES AND APPLY FELT PADS.

7. INSTALL CONTACT ASSEMBLIES USING SUPPLIED SCREWS IN CENTER OF SLOTS.

8a, 8b. PLUG ON CABLE; OR WRAP AND SOLDER YOUR OWN WIRES TO PINS.

9. ADJUST SPEAK POINTS.

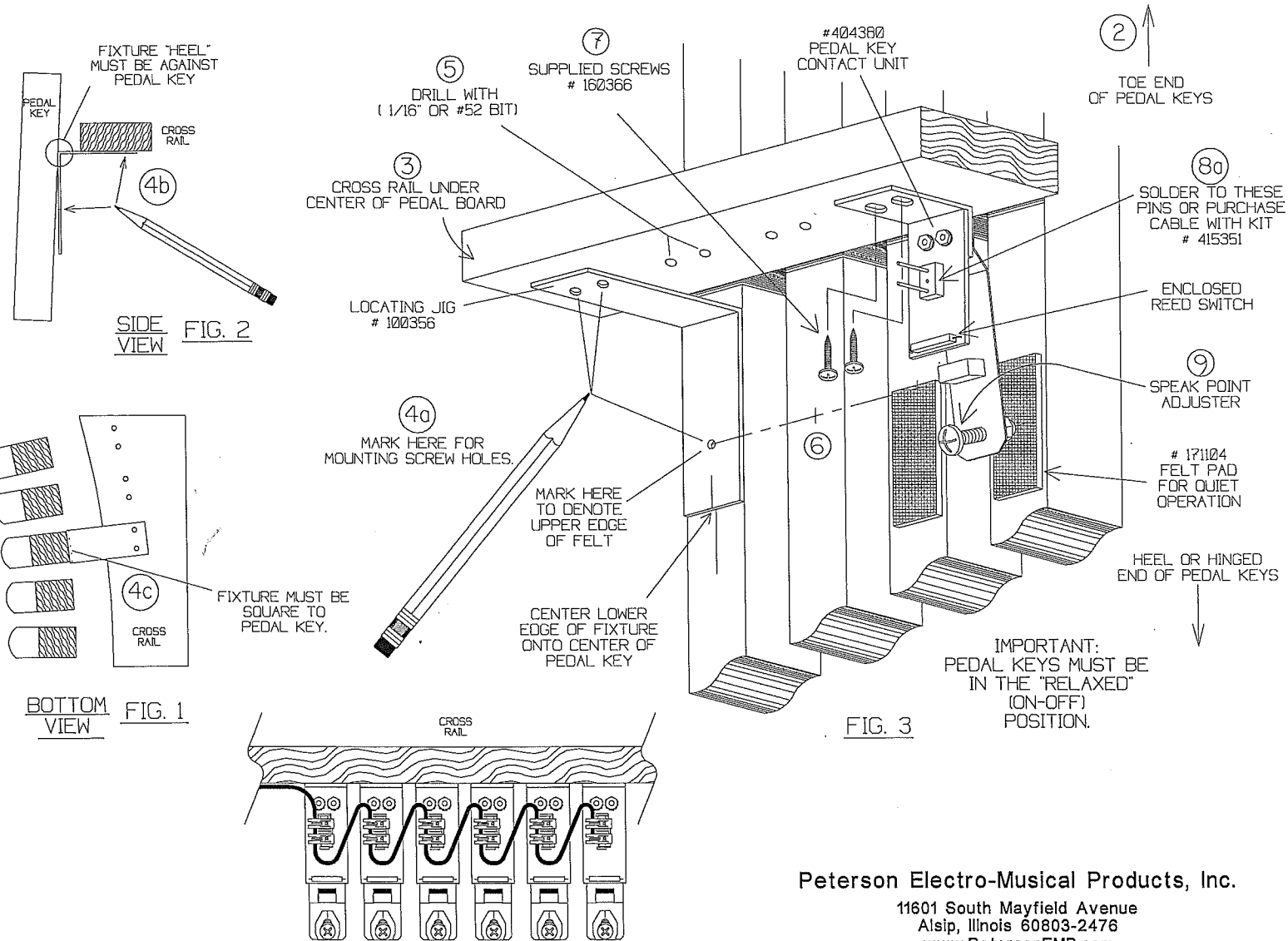

(8b) CONFIGURATION OF OPTIONAL CABLE.