

1. BE SURE TO ORIENT THE PEDAL CONTACT ASSEMBLIES AS SHOWN RELATIVE TO THE TOE AND HEEL ENDS OF THE PEDALBOARD.

2. INSTALL THE CONTACTS AS FAR TO THE TOE END OF THE KEYS AS POSSIBLE BECAUSE THIS WILL MINIMIZE ANY HYSTERESIS.

3. INSTALL CROSS RAIL IF APPLICABLE.

4a, 4b, 4c. USE LOCATING JIG AS SHOWN TO MARK HOLES AND FELT EDGE LOCATIONS.

5. DRILL PILOT HOLES.

6. CLEAN PEDAL KEY SURFACES AND APPLY FELT PADS.

7. INSTALL CONTACT ASSEMBLIES USING SUPPLIED SCREWS IN CENTER OF SLOTS.

8a, 8b. PLUG ON CABLE; OR WRAP AND SOLDER YOUR OWN WIRES TO PINS.

9. ADJUST SPEAK POINTS.

DMG # 190290  
8 1/2" X 14"

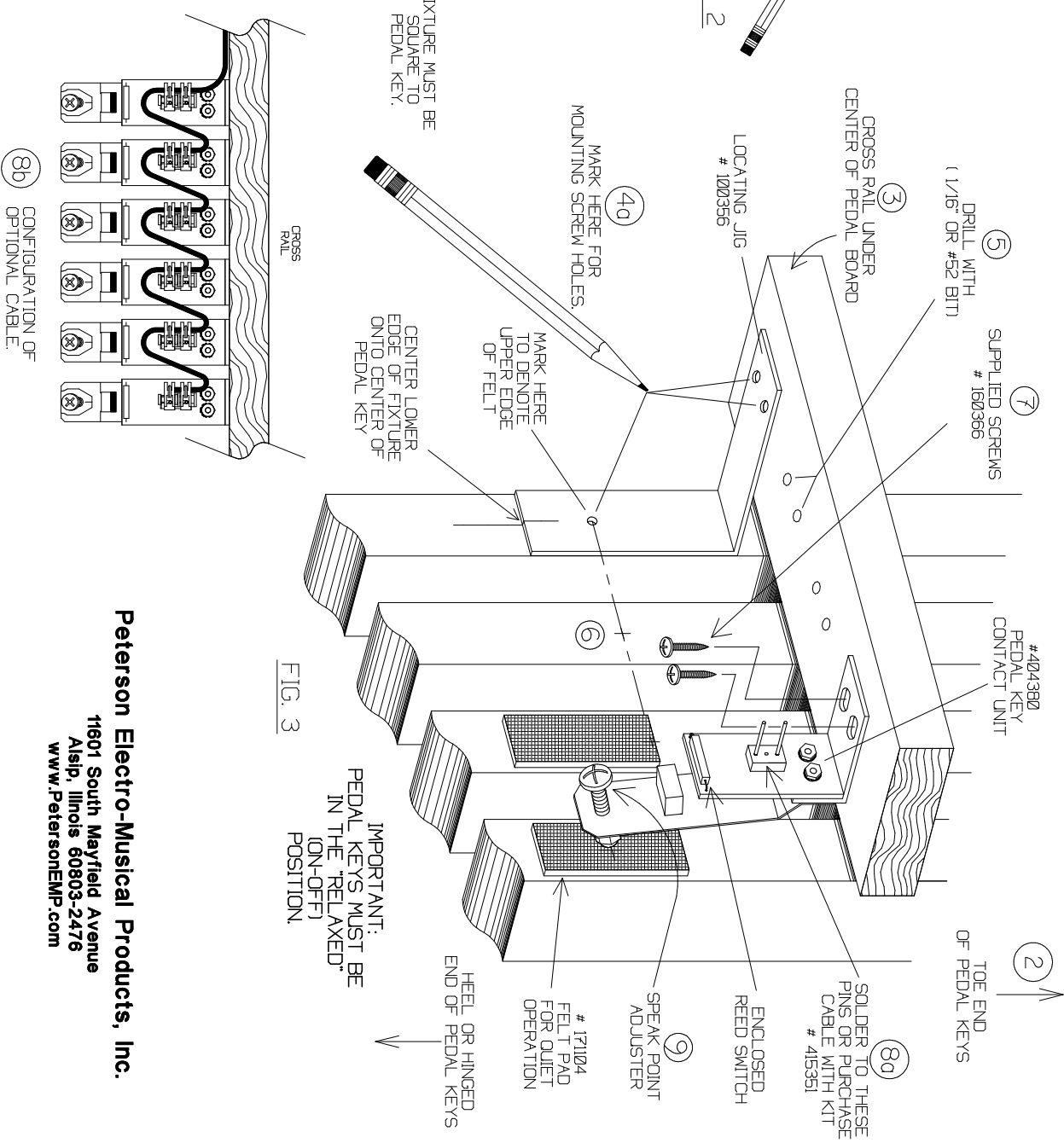
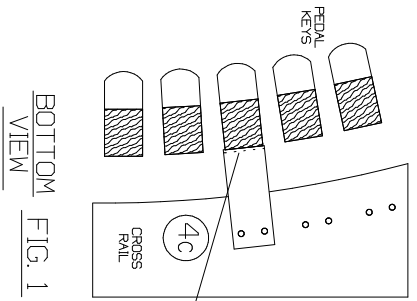
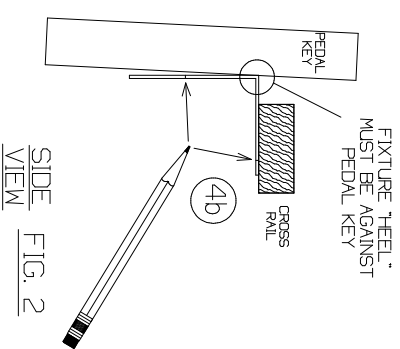

8b  
OPTIONAL CONFIGURATION OF CABLE

IMPORTANT:  
PEDAL KEYS MUST BE  
IN THE "RELAXED"  
(ON-OFF) POSITION.

**Peterson Electro-Musical Products, Inc.**  
11601 South Mayfield Avenue  
Alsip, Illinois 60803-2476  
www.PetersonEMP.com